

Please check the examination details below before entering your candidate information

Candidate surname

Other names

Centre Number

Candidate Number

--	--	--	--	--

--	--	--	--

Pearson Edexcel International GCSE

Time 2 hours

Paper

reference

4BI1/1BR 4SD0/1BR

Biology

UNIT: 4BI1

Science (Double Award) 4SD0

PAPER: 1BR

You must have:

Calculator, ruler

Total Marks

Instructions

- Use **black** ink or ball-point pen.
- **Fill in the boxes** at the top of this page with your name, centre number and candidate number.
- Answer **all** questions.
- Answer the questions in the spaces provided – *there may be more space than you need.*
- Show all the steps in any calculations and state the units.

Information

- The total mark for this paper is 110.
- The marks for **each** question are shown in brackets – *use this as a guide as to how much time to spend on each question.*

Advice

- Read each question carefully before you start to answer it.
- Write your answers neatly and in good English.
- Try to answer every question.
- Check your answers if you have time at the end.

Turn over ►

P69609A

©2022 Pearson Education Ltd.

L:1/1/1/1/1/1/1/





Pearson

Answer ALL questions.

Some questions must be answered with a cross in a box ☒. If you change your mind about an answer, put a line through the box ☒ and then mark your new answer with a cross ☒.

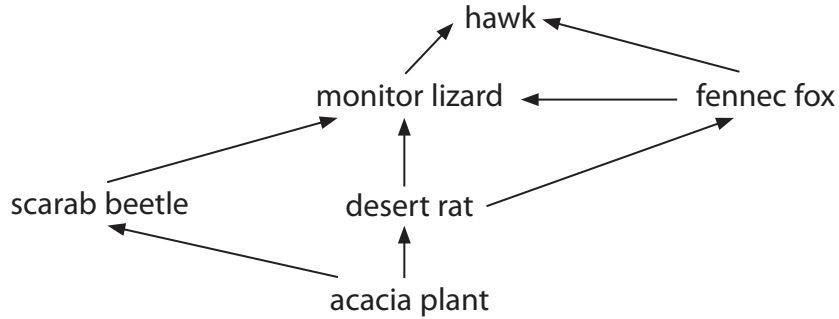
1 The diagram shows part of a food web for a desert community.



(a) (i) How many organisms in this food web are secondary consumers?

(1)

- A** 2
- B** 3
- C** 4
- D** 5

(ii) Draw the longest food chain in this food web.

(1)

(iii) Explain why most of the energy in the producers is **not** transferred to the hawk.

(3)

.....

.....

.....

.....

.....

.....

.....

.....

DO NOT WRITE IN THIS AREA

DO NOT WRITE IN THIS AREA

DO NOT WRITE IN THIS AREA



DO NOT WRITE IN THIS AREA

DO NOT WRITE IN THIS AREA

DO NOT WRITE IN THIS AREA

(b) The photograph shows a fennec fox.



(Source: anolis01.123rf.com/PAL)

Fennec foxes live in the Sahara Desert, which is very hot. They have very large ears and a thin body.

Explain how the body shape of the fennec fox has evolved by natural selection.

(4)

Area with horizontal dotted lines for writing the answer to the question.

(Total for Question 1 = 9 marks)



2 (a) The diagram shows the structure of a human eye.

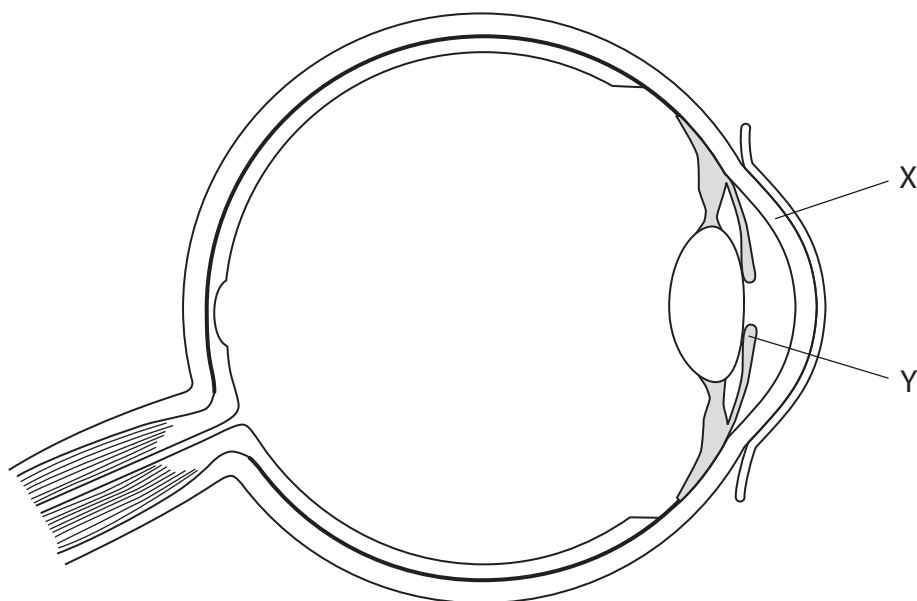

(i) Which of these is the structure labelled X?

(1)

- A** conjunctiva
- B** cornea
- C** lens
- D** retina

(ii) When looking at a close object, which row of the table shows the state of the ciliary muscles and suspensory ligaments?

(1)

	Ciliary muscles	Suspensory ligaments
<input type="checkbox"/> A	contracted	loose
<input type="checkbox"/> B	contracted	tight
<input type="checkbox"/> C	relaxed	loose
<input type="checkbox"/> D	relaxed	tight



(iii) Explain how structure Y controls the light entering the eye when someone walks into a dark room.

(2)

.....

.....

.....

.....

.....

.....

DO NOT WRITE IN THIS AREA

DO NOT WRITE IN THIS AREA

DO NOT WRITE IN THIS AREA



P 6 9 6 0 9 A 0 5 4 0

- (b) Multiple sclerosis is a condition that can slow down the speed at which electrical impulses travel along neurones.

The time taken for the blink reflex to occur can be used to help diagnose if someone has multiple sclerosis.

The blink reflex causes the eyelid to close.

Air is blown on to the eye and the time taken for the eyelid to close is recorded.

The diagram shows the reflex pathway.

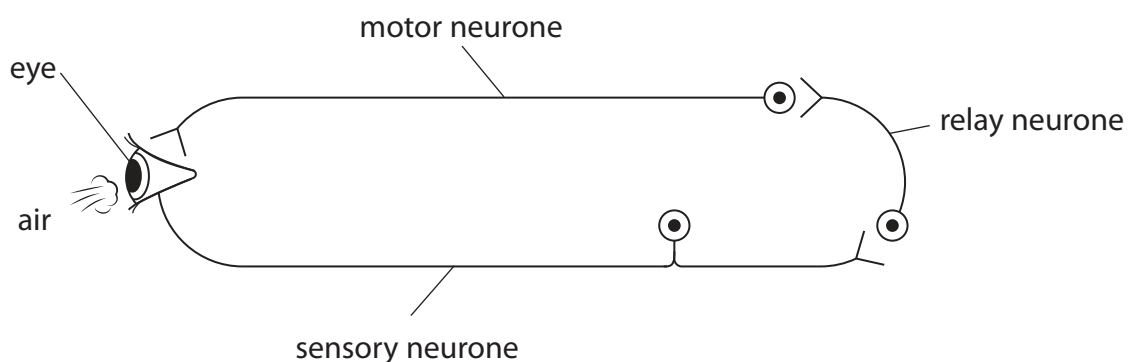

The speed the impulse moves along the reflex arc consisting of all three neurones in a person without multiple sclerosis is 77 metres per second.

The time taken for the blink reflex to occur in a person with multiple sclerosis is 0.0050 s.

The total length of the neurones in the reflex arc for the person with multiple sclerosis is 25 cm.

- (i) Calculate the difference between the speed of impulse for the person with multiple sclerosis and for the person without multiple sclerosis, in metres per second.

(3)

..... m/s



(ii) The speed of an impulse along the axon of the motor neurone for someone without multiple sclerosis is 120 metres per second.

Suggest why the speed of the impulse calculated along all three neurones is less than the speed of the impulse along only the motor neurone.

(2)

.....

.....

.....

.....

(Total for Question 2 = 9 marks)

DO NOT WRITE IN THIS AREA

DO NOT WRITE IN THIS AREA

DO NOT WRITE IN THIS AREA



DO NOT WRITE IN THIS AREA

DO NOT WRITE IN THIS AREA

DO NOT WRITE IN THIS AREA

BLANK PAGE



3 The diagram shows a yeast cell.

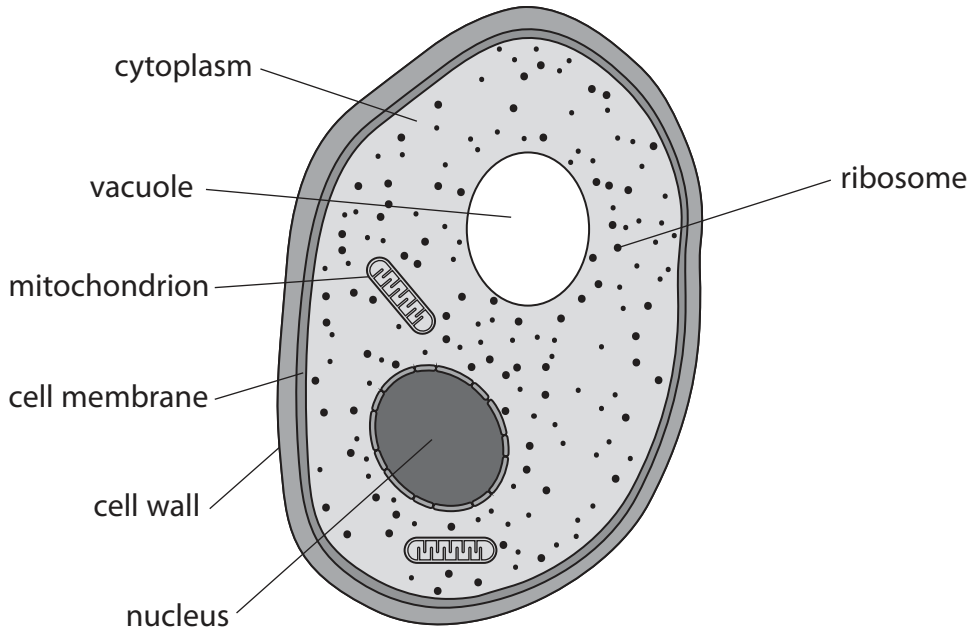

(Source: Pearson Education Ltd)

(a) (i) In which of the labelled structures in the yeast cell does aerobic respiration occur?

(1)

- A mitochondrion
- B nucleus
- C ribosome
- D vacuole

(ii) What substance is the yeast cell wall made of?

(1)

- A cellulose
- B chitin
- C glycogen
- D starch

(iii) Which of these structures found in the yeast cell would also be present in a prokaryotic cell?

(1)

- A cell membrane
- B mitochondrion
- C nucleus
- D vacuole



(b) Yeast cells are often used when making bread.

A student uses this method to investigate the effect of temperature on the height that bread dough rises.

- place dough containing flour, sugar, water and yeast into a measuring cylinder
- measure the height of the dough
- place the measuring cylinder in a 25°C water bath
- measure the height of the dough after two hours
- repeat the experiment at temperatures of 35°C and 65°C

The diagram shows the student's apparatus.

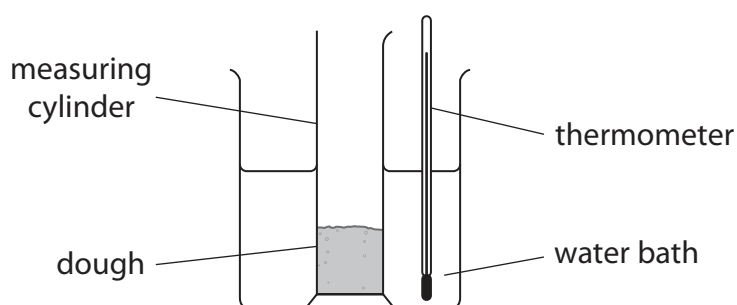

The table shows the student's results.

Temperature in °C	Height of dough in mm		Percentage (%) increase in height of dough
	at start	after two hours	
25	25	35	40
35	25	45	
65	25	27	8

(i) Calculate the percentage increase in the height of the dough after two hours at a temperature of 35°C.

(2)

percentage increase = %



(ii) Explain why yeast causes the bread dough to increase in height.

(2)

.....

.....

.....

.....

.....

.....

(iii) Explain why the dough rises to a different height at 25 °C compared with the height at 35 °C.

(2)

.....

.....

.....

.....

(iv) Explain why the dough rises to a different height at 35 °C compared with the height at 65 °C.

(2)

.....

.....

.....

.....

(Total for Question 3 = 11 marks)

DO NOT WRITE IN THIS AREA

DO NOT WRITE IN THIS AREA

DO NOT WRITE IN THIS AREA



4 The diagram shows the human alimentary canal.

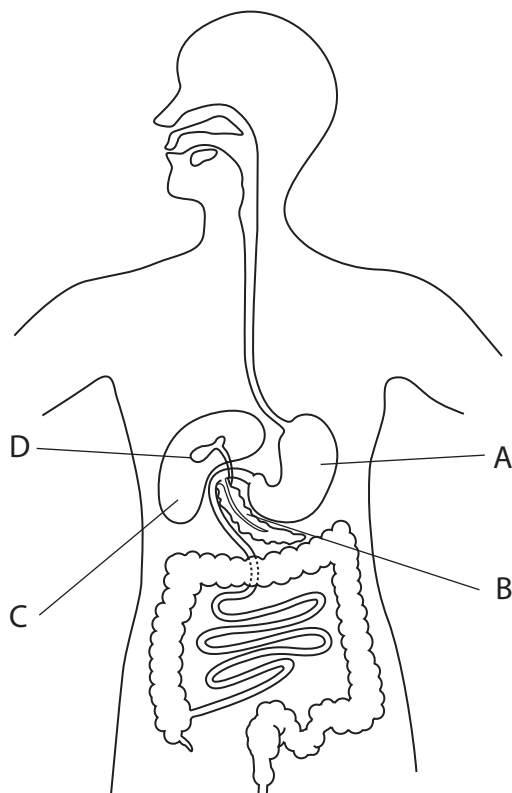

(a) (i) Explain how food passes down the oesophagus.

(2)

.....

.....

.....

.....

(ii) Which labelled structure produces bile?

(1)

- A
- B
- C
- D



(iii) Describe the role of bile in digestion.

(3)

DO NOT WRITE IN THIS AREA

DO NOT WRITE IN THIS AREA

DO NOT WRITE IN THIS AREA

Handwriting practice area with ten horizontal dotted lines for writing the answer.



(b) Lipase inhibitors are chemicals that bind to lipase enzymes.

To test the effect of a lipase inhibitor, equal masses of full fat milk are placed into two test tubes.

Lipase inhibitor is added to one test tube.

Lipase is added to both test tubes and the pH of each solution is measured every five minutes.

The results are shown in the table.

Time in minutes	pH of solution	
	without lipase inhibitor	with lipase inhibitor
0	8.0	8.0
5	7.6	7.8
10	7.2	7.8
15	6.3	7.7
20	5.8	7.5

(i) Calculate the mean rate of pH change per minute of the solution without lipase inhibitor.

(2)

mean rate of pH change = per minute



(ii) Explain the difference in the changes of pH of the solutions in the two test tubes during the 20-minute period.

(2)

.....

.....

.....

.....

.....

DO NOT WRITE IN THIS AREA

DO NOT WRITE IN THIS AREA

DO NOT WRITE IN THIS AREA



P 6 9 6 0 9 A 0 1 5 4 0

(iii) Doctors use this method to investigate the use of lipase inhibitor as a treatment for obesity.

- give three volunteers a tablet containing the lipase inhibitor
- give another three volunteers a tablet with no lipase inhibitor
- give all the volunteers 100 cm^3 of olive oil to drink
- measure the lipid concentrations in the blood of the volunteers after three hours

Some of the volunteers reported abdominal pains three hours after drinking the olive oil.

The table shows the doctors' results.

Tablet contents	Blood lipid concentration in mg per dm^3		Abdominal pains
	at start	after 3 hours	
inhibitor	35	38	yes
inhibitor	37	42	no
inhibitor	37	43	yes
no inhibitor	35	62	no
no inhibitor	37	64	no
no inhibitor	35	45	yes



- 5 Mycoprotein is protein produced by fungi that can be made into meat substitutes. Large amounts of fungus are grown in fermenters to produce the mycoprotein. The diagram shows a typical mycoprotein fermenter.

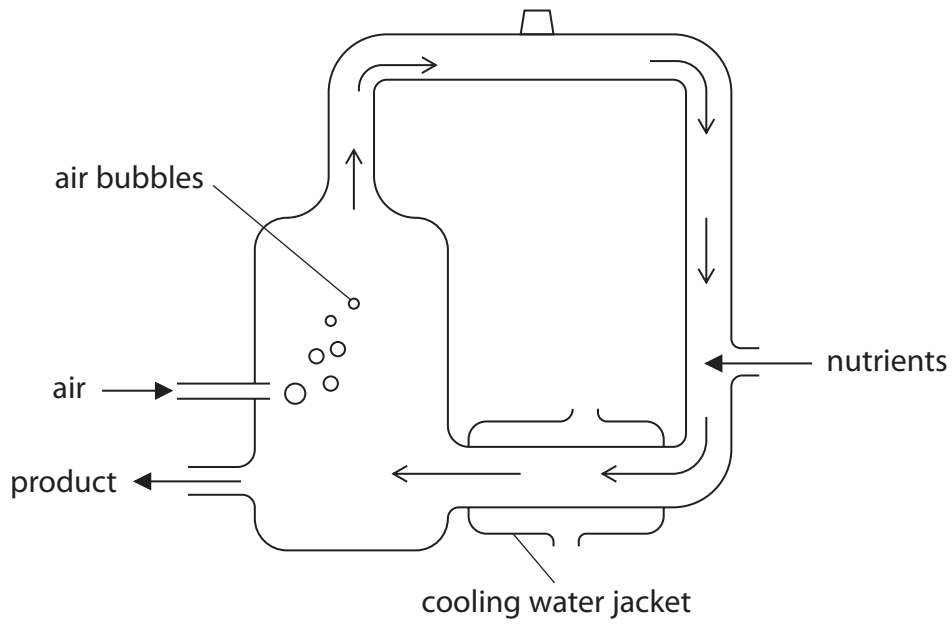

DO NOT WRITE IN THIS AREA

DO NOT WRITE IN THIS AREA

DO NOT WRITE IN THIS AREA



DO NOT WRITE IN THIS AREA

DO NOT WRITE IN THIS AREA

DO NOT WRITE IN THIS AREA

(a) (i) Explain why air is bubbled into the fermenter.

(2)

.....

.....

.....

.....

(ii) Explain why the fermenter is cleaned using steam before the fungus and nutrients are added.

(2)

.....

.....

.....

.....



P 6 9 6 0 9 A 0 1 9 4 0

- (b) A scientist investigates the production of mycoprotein by a genetically modified (GM) fungus and a non-genetically modified fungus (non-GM).

The scientist claims that the GM fungus will be better for large-scale production of mycoprotein.

The scientist measures the mass of mycoprotein produced by the fungi in fermenters for 30 days.

The table shows the scientist's results.

Time in days	Mass of mycoprotein produced in kg	
	GM fungus	Non-GM fungus
5	130	125
10	220	190
15	330	270
20	420	360
30	430	460



- (i) Plot a line graph to show how the mass of mycoprotein changes over the 30 days for each type of fungus.

Use a ruler to join the points with straight lines.

(5)

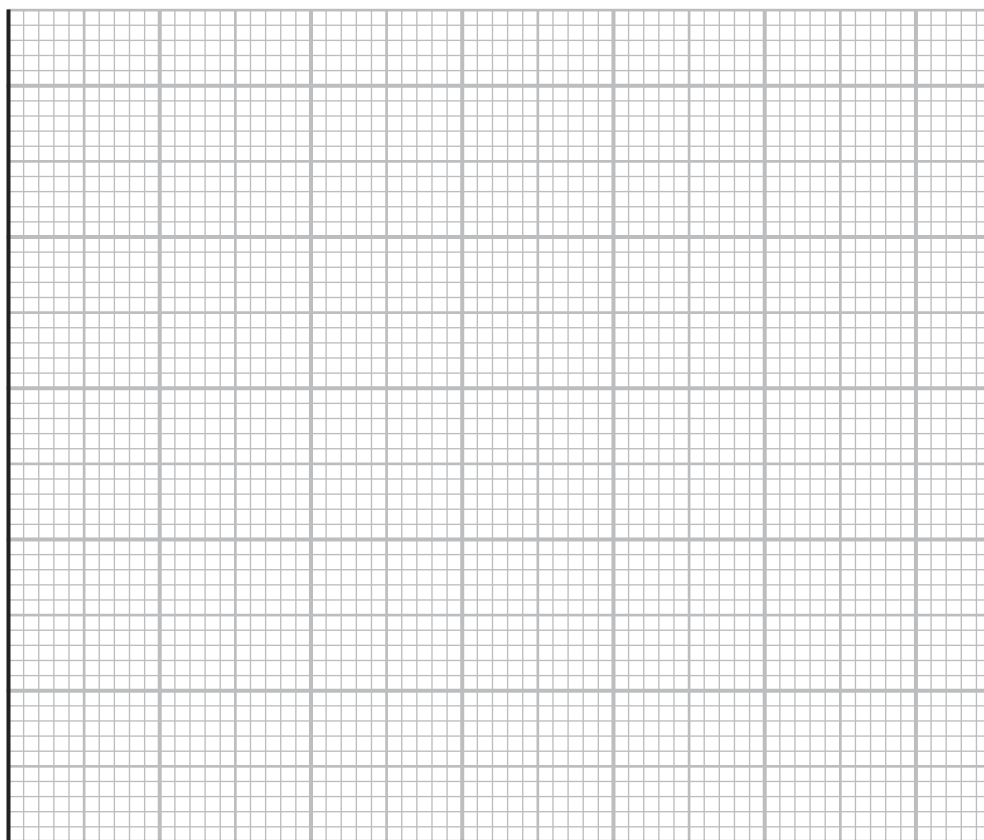

- (ii) The scientist claims that the GM fungus will be better for large-scale production of mycoprotein than the non-GM fungus.

Comment on the scientist's claim.

(2)

.....

.....

.....

.....

DO NOT WRITE IN THIS AREA

DO NOT WRITE IN THIS AREA

DO NOT WRITE IN THIS AREA



(iii) The table shows the nutritional composition of mycoprotein and the nutritional composition of lamb.

Nutritional component	Mass of nutritional component in 100 grams of food in grams	
	mycoprotein	lamb
protein	10.5	20.2
cholesterol	0.0	0.1
fat	3.0	25.5
fibre	6.0	0.7
iron	0.00039	0.0025
calcium	0.048	0.010

DO NOT WRITE IN THIS AREA

DO NOT WRITE IN THIS AREA

DO NOT WRITE IN THIS AREA



Discuss whether eating mycoprotein is more healthy than eating lamb for a growing human.

(5)

DO NOT WRITE IN THIS AREA

DO NOT WRITE IN THIS AREA

DO NOT WRITE IN THIS AREA

DO NOT WRITE IN THIS AREA

DO NOT WRITE IN THIS AREA

DO NOT WRITE IN THIS AREA

DO NOT WRITE IN THIS AREA

DO NOT WRITE IN THIS AREA

DO NOT WRITE IN THIS AREA

DO NOT WRITE IN THIS AREA

DO NOT WRITE IN THIS AREA

DO NOT WRITE IN THIS AREA

DO NOT WRITE IN THIS AREA

DO NOT WRITE IN THIS AREA

DO NOT WRITE IN THIS AREA

DO NOT WRITE IN THIS AREA

DO NOT WRITE IN THIS AREA

DO NOT WRITE IN THIS AREA

DO NOT WRITE IN THIS AREA

DO NOT WRITE IN THIS AREA

(Total for Question 5 = 16 marks)



DO NOT WRITE IN THIS AREA

DO NOT WRITE IN THIS AREA

DO NOT WRITE IN THIS AREA

BLANK PAGE



DO NOT WRITE IN THIS AREA

DO NOT WRITE IN THIS AREA

DO NOT WRITE IN THIS AREA

6 The diagram shows the human female reproductive system.

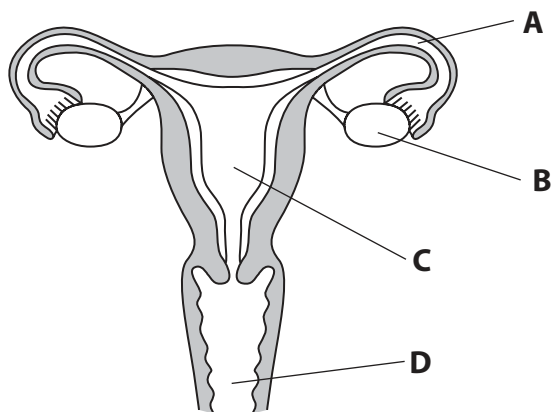

(a) (i) Which label shows where ovulation occurs?

(1)

- A
- B
- C
- D

(ii) Which label shows where fertilisation usually occurs?

(1)

- A
- B
- C
- D



(b) The diagram shows the changes in thickness of the uterus lining and levels of two hormones produced by the ovary during a menstrual cycle.

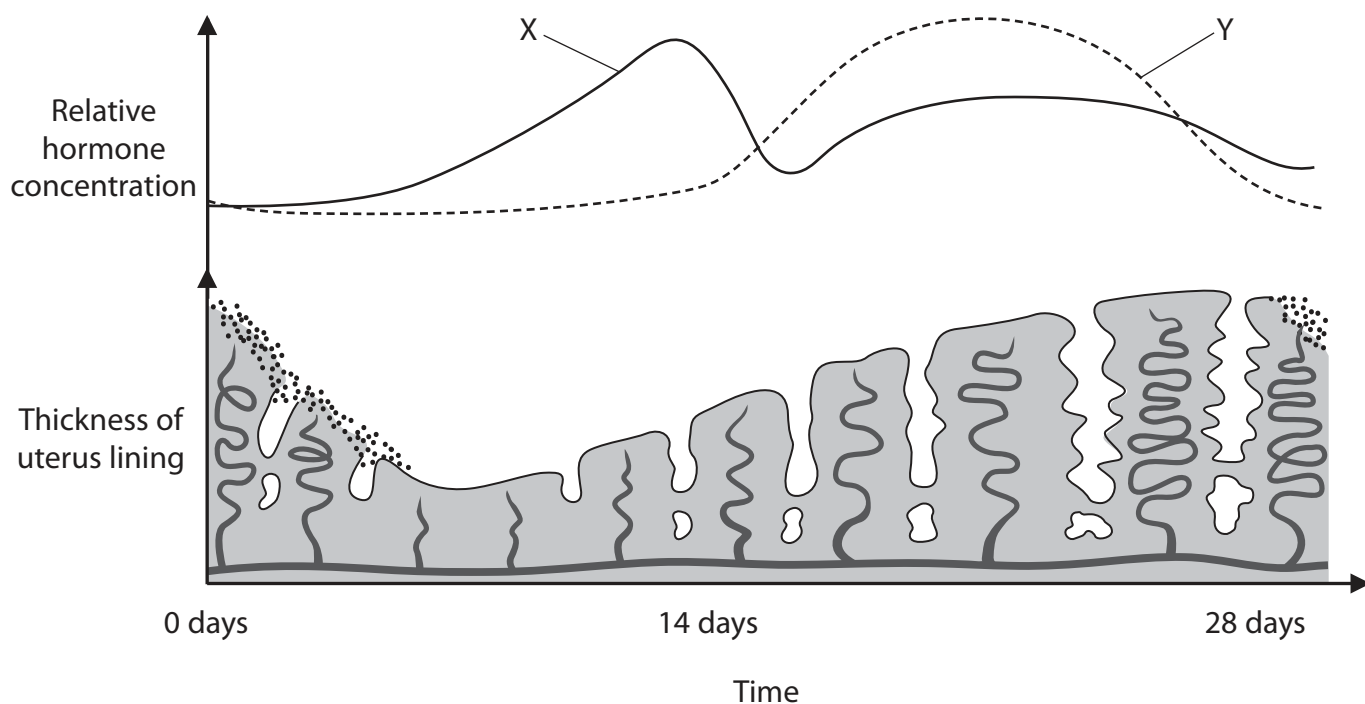

(i) Hormones X and Y are produced by the ovaries.

Name X and Y.

(2)

X

Y

(ii) Explain the function of hormone X during the menstrual cycle.

(2)

.....
.....
.....
.....



DO NOT WRITE IN THIS AREA

DO NOT WRITE IN THIS AREA

DO NOT WRITE IN THIS AREA

(c) The diagram shows a human fetus developing in the uterus.

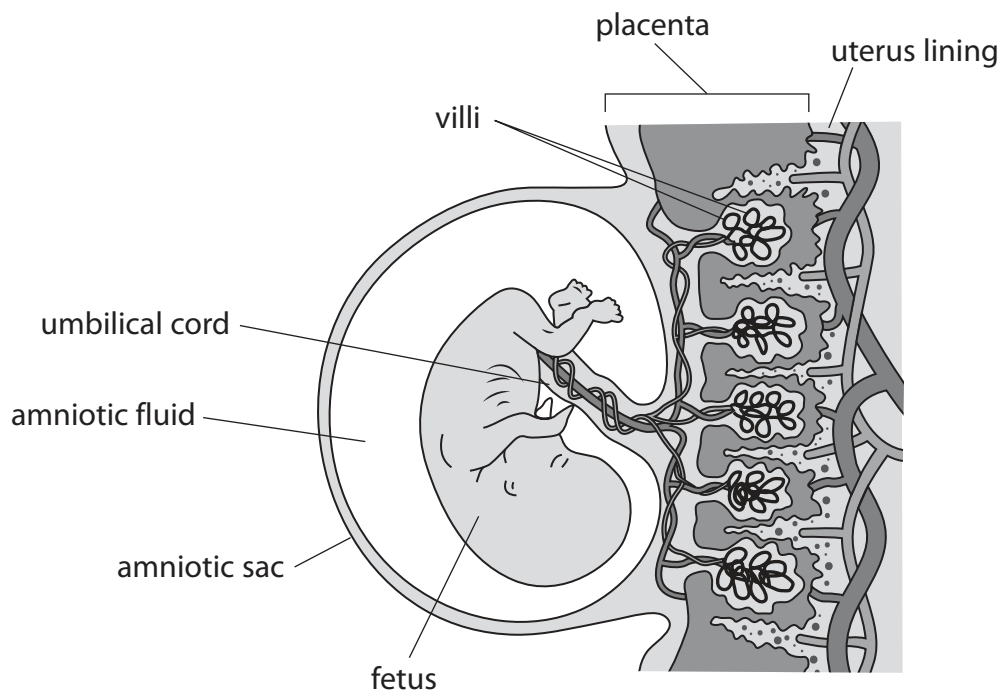

Explain how the structure of the placenta enables the efficient exchange of substances between the fetus and the mother.

(3)

.....

.....

.....

.....

.....

.....

.....

(Total for Question 6 = 9 marks)



- 7 Hypertrophic myopathy is a heart condition that can affect some cats. It is caused by a dominant allele.

Hypertrophic myopathy causes the left ventricle wall of the heart to be less elastic.

- (a) (i) Explain why cats with hypertrophic myopathy are unable to run quickly.

(2)

.....

.....

.....

.....

- (ii) State what is meant by a dominant allele.

(1)

.....

.....

- (iii) The diagram shows a family pedigree for cats with and without hypertrophic myopathy.

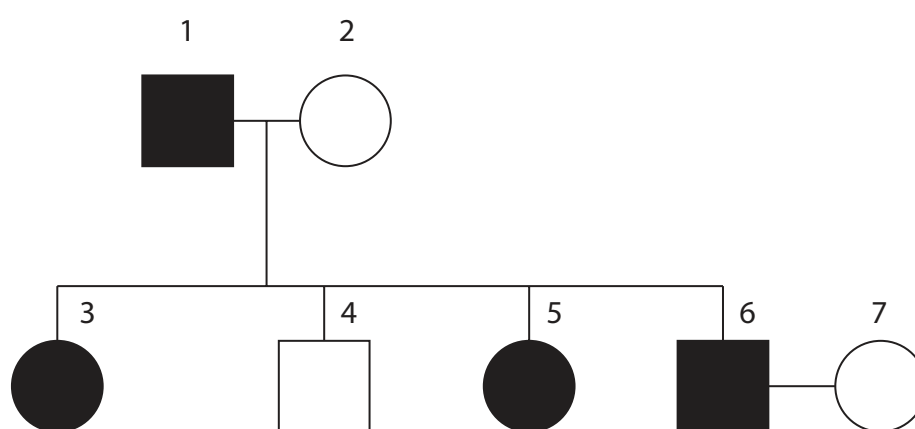

Key



male with hypertrophic myopathy



male without hypertrophic myopathy



female with hypertrophic myopathy



female without hypertrophic myopathy



Draw a genetic diagram to show the possible genotypes and phenotypes of the offspring produced by individuals 6 and 7.

Use **H** as the allele for hypertrophic myopathy and **h** as the allele for normal heart development.

(4)

(iv) Calculate the probability that the next offspring produced by individuals 6 and 7 is male and has hypertrophic myopathy.

(1)

probability =

(b) Cat breeders often try to remove harmful alleles from populations by selective breeding.

Suggest why it is more difficult to remove harmful recessive alleles from populations than harmful dominant alleles from populations.

(2)

.....

.....

.....

.....

(Total for Question 7 = 10 marks)



8 A student investigates the effect of light intensity on photosynthesis in leaf discs.

This is the student's method.

- cut equal sized discs from a leaf
- remove the plunger from a 20 cm³ syringe and place a disc into the syringe
- replace the plunger in the syringe and fill the syringe with 2% sodium hydrogen carbonate solution, which provides carbon dioxide
- place thumb over the end of the syringe and pull the plunger back until the disc sinks
- position the syringe vertically
- place a lamp five centimetres from the syringe
- record the time taken for the leaf disc to rise to the top of the syringe
- repeat the experiment with the lamp at increasing distances from the syringe

The leaf discs rise in the solution due to the production of gas during photosynthesis.

The diagram shows some of the apparatus used.

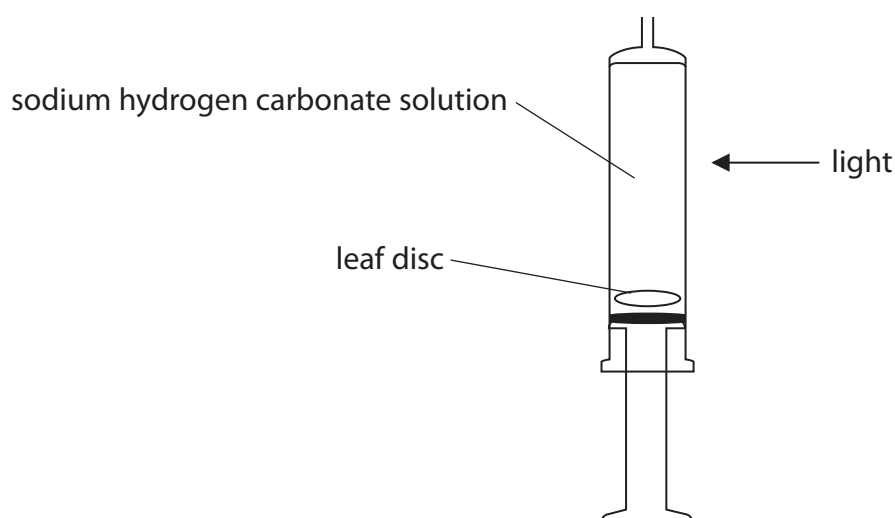

(a) Give the balanced chemical symbol equation for photosynthesis.

(2)

(b) (i) State how the student could improve the reliability of their results.

(1)



(ii) Give the dependent variable in the investigation.

(1)

(c) The graph shows the results of the investigation.

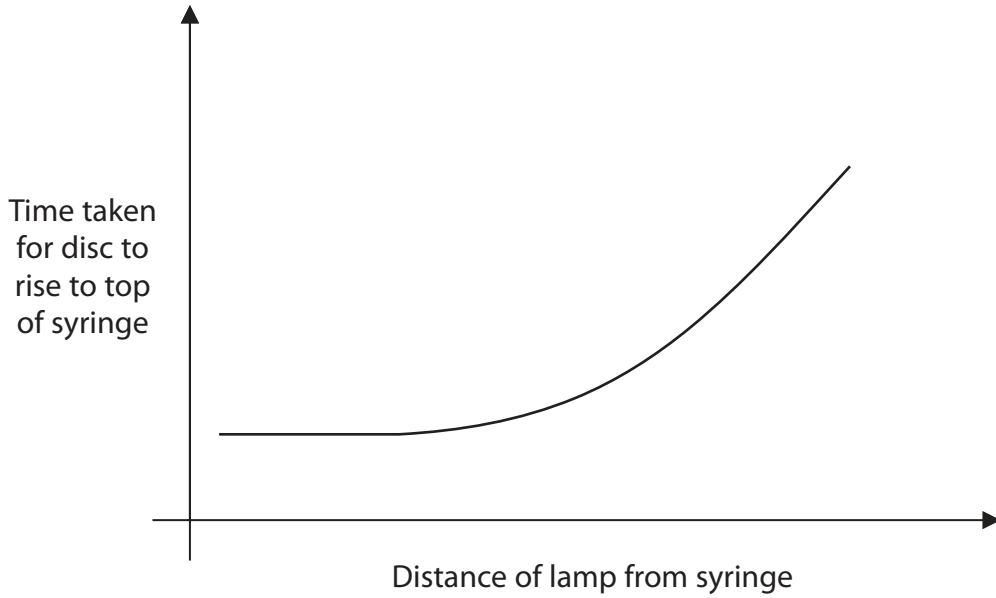

Explain the effect of increasing the distance of the lamp on the time taken for the leaf disc to rise to the top of the syringe.

(4)

DO NOT WRITE IN THIS AREA

DO NOT WRITE IN THIS AREA

DO NOT WRITE IN THIS AREA



(d) Describe how the student could test the leaf discs for the presence of starch.

(3)

.....

.....

.....

.....

.....

.....

.....

.....

(Total for Question 8 = 11 marks)

DO NOT WRITE IN THIS AREA

DO NOT WRITE IN THIS AREA

DO NOT WRITE IN THIS AREA



DO NOT WRITE IN THIS AREA

DO NOT WRITE IN THIS AREA

DO NOT WRITE IN THIS AREA

BLANK PAGE



P 6 9 6 0 9 A 0 3 3 4 0

- 9 Large quantities of food are wasted every year. Waste food needs to be disposed of using methods that do not harm the environment.

The table shows the mass of each gas released into the air from three different methods of waste disposal.

Method of waste disposal	Mass of each gas released into the air from 1000 kg of waste food in kg			
	carbon dioxide	carbon monoxide	methane	sulfur dioxide
anaerobic digester	37	0.012	3.05	0.23
burying in landfill	220	0.680	14.70	0.14
burning	680	0.059	3.12	0.08

- (a) Calculate how much carbon dioxide would be released from 125 kg of waste food when using an anaerobic digester.

Give your answer to two significant figures.

(2)

mass of carbon dioxide released = kg



(b) Some scientists have claimed that anaerobic digesters are the most environmentally friendly method of waste disposal.

Evaluate this claim using data from the table and your own knowledge.

(5)

DO NOT WRITE IN THIS AREA

DO NOT WRITE IN THIS AREA

DO NOT WRITE IN THIS AREA

Area with horizontal dotted lines for writing.

(Total for Question 9 = 7 marks)



P 6 9 6 0 9 A 0 3 5 4 0

10 The diagram shows the human thorax.

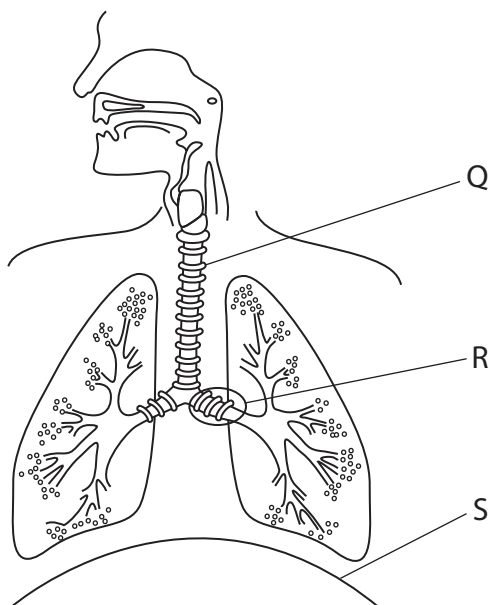

(a) (i) Which of these are structures Q and R?

(1)

	Q	R
<input type="checkbox"/> A	bronchiole	trachea
<input type="checkbox"/> B	bronchus	trachea
<input type="checkbox"/> C	trachea	bronchiole
<input type="checkbox"/> D	trachea	bronchus

(ii) Explain how structure S helps a person to exhale.

(3)

.....

.....

.....

.....

.....

.....

(b) The graph shows how the volume of air exhaled varies with time during one breath.

This is shown for a person with a lung disease and a person with healthy lungs.

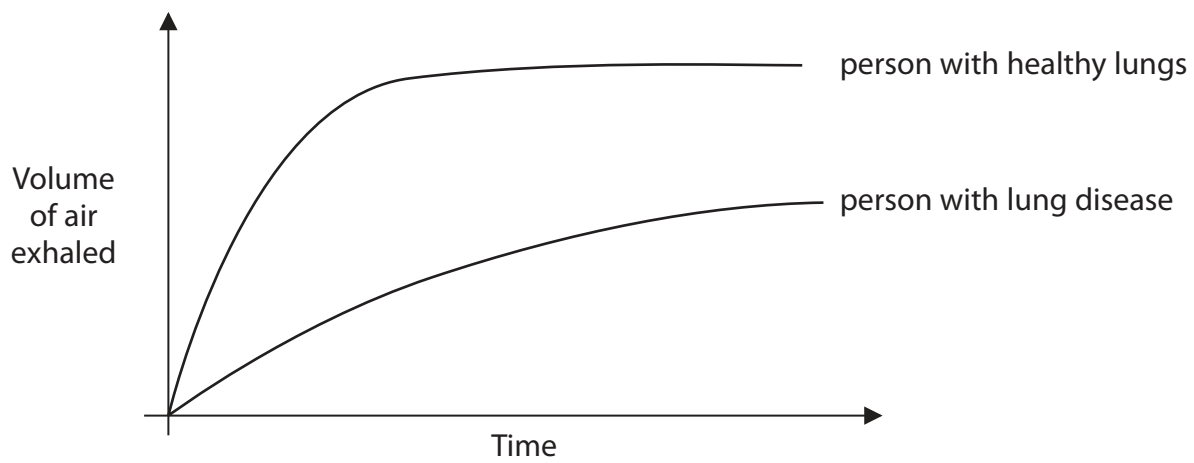

Explain why the person with lung disease is often breathless and unable to exercise.

(3)

.....

.....

.....

.....

.....

.....

.....

.....

.....

.....

(Total for Question 10 = 7 marks)



11 The photograph shows a small animal called a woodlouse.

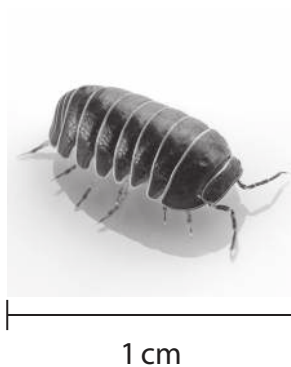

(Source: paulrommer. Shutterstock/PAL)

Woodlice often live under pieces of dead wood in dark, humid conditions.

Design an investigation to find out if light intensity affects the speed at which woodlice move.

Include experimental details in your answer and write in full sentences.

(6)

.....

.....

.....

.....

.....

.....

.....

.....

.....

.....

.....

.....

.....

.....

.....

.....

.....

.....

.....

.....

.....

.....

DO NOT WRITE IN THIS AREA

DO NOT WRITE IN THIS AREA

DO NOT WRITE IN THIS AREA

Handwriting practice area with ten horizontal dotted lines.

(Total for Question 11 = 6 marks)

TOTAL FOR PAPER = 110 MARKS



DO NOT WRITE IN THIS AREA

DO NOT WRITE IN THIS AREA

DO NOT WRITE IN THIS AREA

BLANK PAGE

